

Combination Knock-Out Pot/Inlet Filter

Busch Knock-Out Pots are designed with low pressure drop for vacuum service and to provide a high degree of protection for your Busch vacuum pump.

Removing liquids and solid particulate from the process gas dramatically reduces pump oil contamination, improves the operating efficiency, and extends pump life.

The separation of entrained

materials from the gas stream is accomplished in three stages. In the first stage, the bulk liquid is separated from the gas by the initial tangential flow of the gas stream into the vessel.

In the second stage, the demister pad removes the mist/fog and also acts as a prefilter which removes larger solid particulates.

The third stage of the combination unit is a particulate filter which removes solids down to 10

microns. The filter and demister pad are easily accessible through a removable lid.

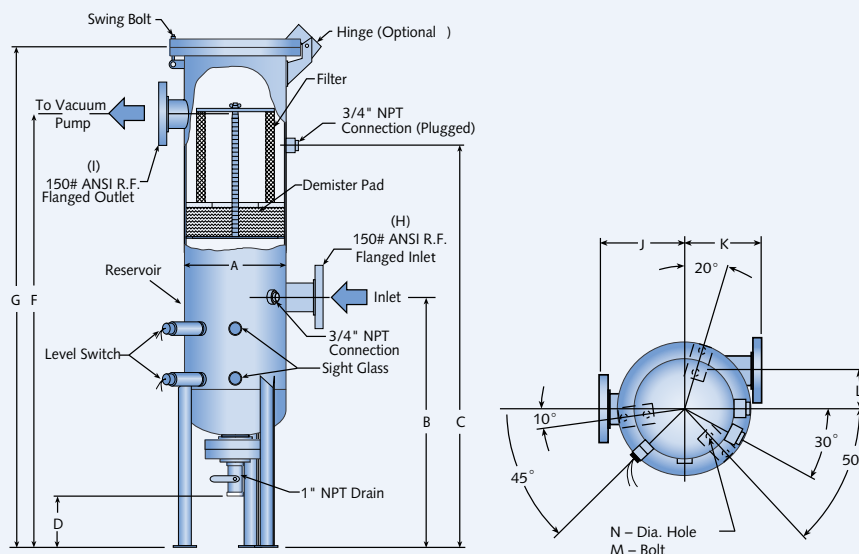

Dimensions	A	B	C	D	F	G	H	I	J	K	L	M	N	Total Vol. (gallons)	Condensate Vol. (gallons)	Shipping Weight (lbs)
U 8	8 ⁵ / ₈	35	45	9	51	56 ¹ / ₂	2"-150#	2"-150#	8	8	2 ⁷ / ₈	7 ³ / ₄	11 ¹ / ₁₆	8	3	250
U 12	12 ³ / ₄	41	59	9	63	70 ¹ / ₂	3"-150#	3"-150#	10 ¹ / ₂	10 ¹ / ₂	4 ⁵ / ₈	9 ¹ / ₄	1	25	9	475
U 16	16	41	69	9	73	81 ¹¹ / ₁₆	4"-150#	4"-150#	14	14	5 ⁷ / ₁₆	12	1	49	15	650
U 24	24	47	75	9	81	93	6"-150#	6"-150#	18	18	8 ¹¹ / ₁₆	21 ¹ / ₂	1	136	42	1100

Filter Features:

- Space saving, single housing design for both liquid separation and solid filtration
- Easy, full access, swing bolt retained lid for internal inspection and cleaning
- Stainless steel demister pad
- Viton gaskets and 150# raised face flanged process connections
- Carbon steel housing, designed and tested for vacuum service.
- Housing self-supporting with legs for free standing installation

- NEMA 7 liquid level switches
- Sight glasses and manual liquid drain valve
- 10 micron polypropylene particulate filter

Available Options:

- Hinged lid
- ASME certification
- Available in a wide range of materials to meet special process requirements

