

Two Stage Vacuum Inlet Filter

Busch two-stage vacuum inlet filters are designed to provide a degree of protection for vacuum pumps that extends beyond that provided by standard inlet filters.

Applications where fine particulates are present often require high efficiency or HEPA filters. Such filters also require pre-filters to filter out the bulk of the product and to keep the higher efficiency filters from being

overloaded. This overloading would quickly block the entire element, thus reducing the amount of vacuum being pulled on the process by the vacuum pump.

Busch two stage vacuum inlet filters consist of a 10 micron polyester pre-filter and an industrial grade high efficiency after-filter made from glass fibers with urethane endcaps. There is a

choice of 2 filtration levels; 98% retention of all particles .3 microns in size or larger or 99.97% retention of all particles .3 microns in size or larger.

The filter may be installed in either a horizontal or vertical position.

The Busch two-stage vacuum inlet filter is intended for use with Busch pumps of up to 500 CFM displacement.

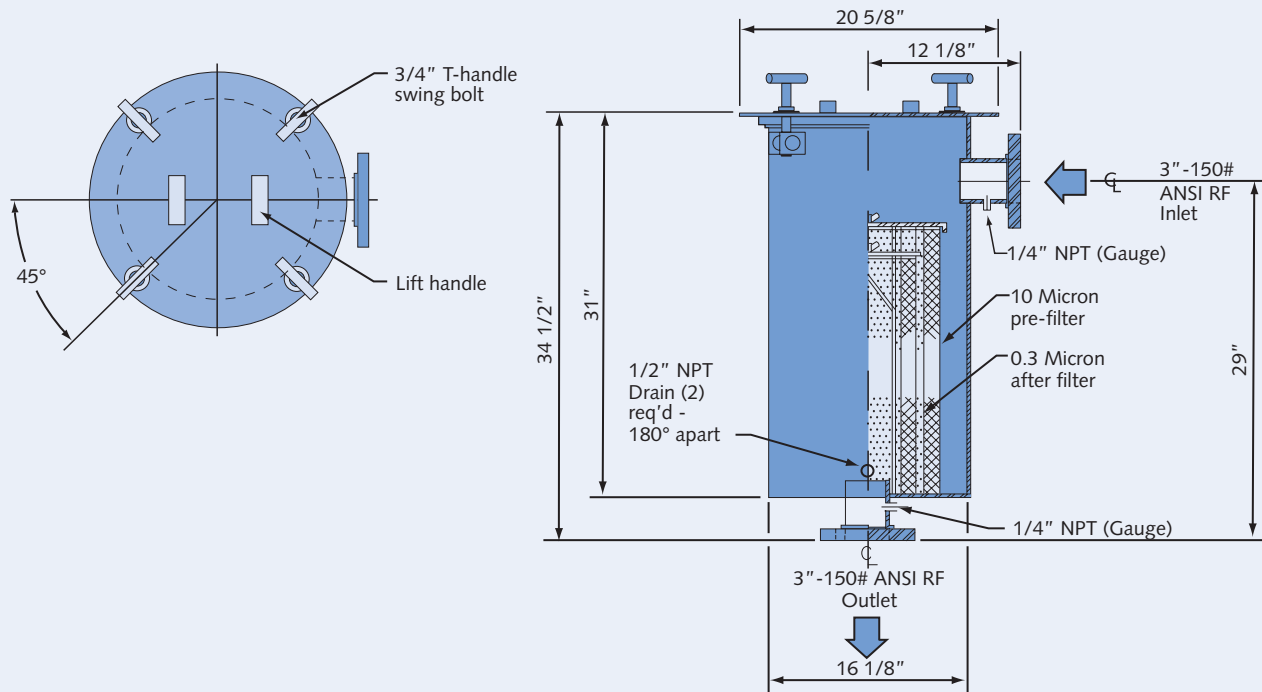

Filter Features:

- Two-in-one design
- EPDM gasket sealed
- Easy filter element change-out
- Differential pressure ports
- Carbon steel construction
- Optional materials available

