

# Chemical Resistant Vacuum Gauge

The chemical resistant (Model CCR) vacuum gauge has been designed for applications where chemical contamination exists. The sensing element, vacuum chamber and connection port are manufactured from corrosion-resistant materials. The gauge movement, dial, and pointer are isolated from the medium to be measured. Positive pressure up to two bar will not cause damage or alter the calibration.

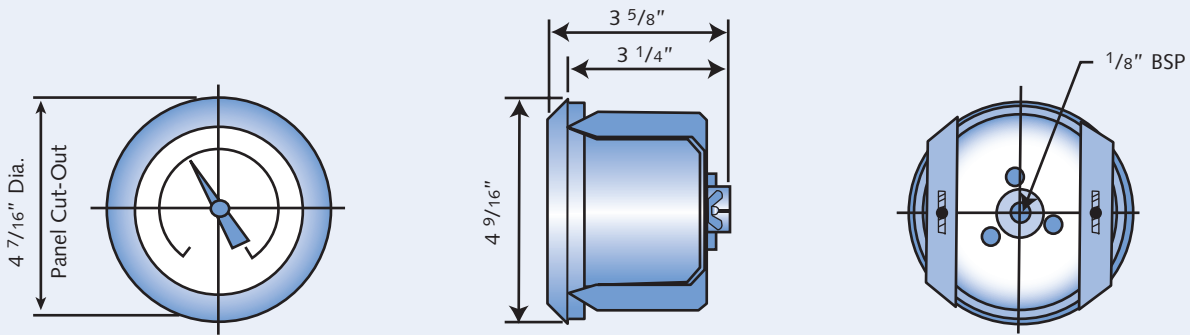

## Technical Data

Model	CCR 100	CCR 760
Range	0-100 torr	0-760 torr
Graduations	2 torr	10 torr
Figure Interval	10 torr	100 torr
Accuracy	± 2% of full scale	± 2% of full scale
Scale length	6.5 inches	6.5 inches
Internal volume	7.2 in <sup>3</sup>	7.2 in <sup>3</sup>
Weight	2.1 lbs.	2.1 lbs.
Capsule	Manufactured from Inconel X750	Manufactured from Inconel X750

